

Perno Small Hanging Shade

CP1401 | 1.0

GENERATION LIGHTING
PENDANT

GENERAL PRODUCT INFORMATION:

These fixtures are intended to be installed utilizing NEC compliant junction boxes.

This product is safety listed for damp locations.

Incandescent version may be dimmed with a standard incandescent dimmer. LED version may be dimmed with a LED dimmer. Consult lamp manufacturer for additional information.

This instruction shows a typical installation.

CAUTION - RISK OF FIRE

This product must be installed in accordance with the applicable installation code by a person familiar with the construction and operation of the product and the hazards involved.

Use minimum 90°C supply conductors.

SAVE THESE INSTRUCTIONS!

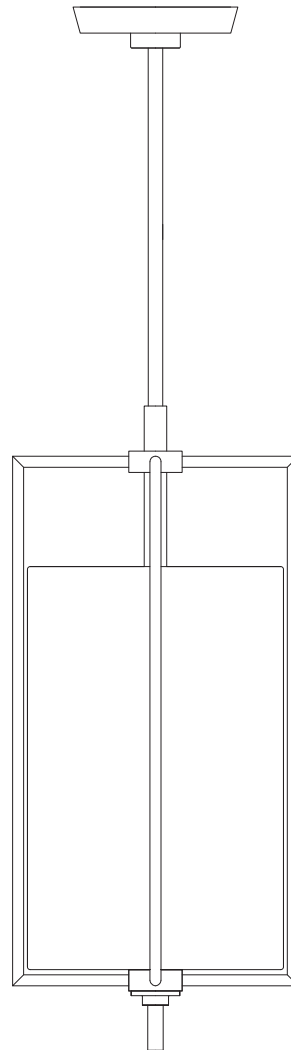

GENERATION LIGHTING
7400 Linder Ave., Skokie, IL 60077
T 847.410.4400 | F 847.410.4500
www.generationlighting.com

Install the Fixture

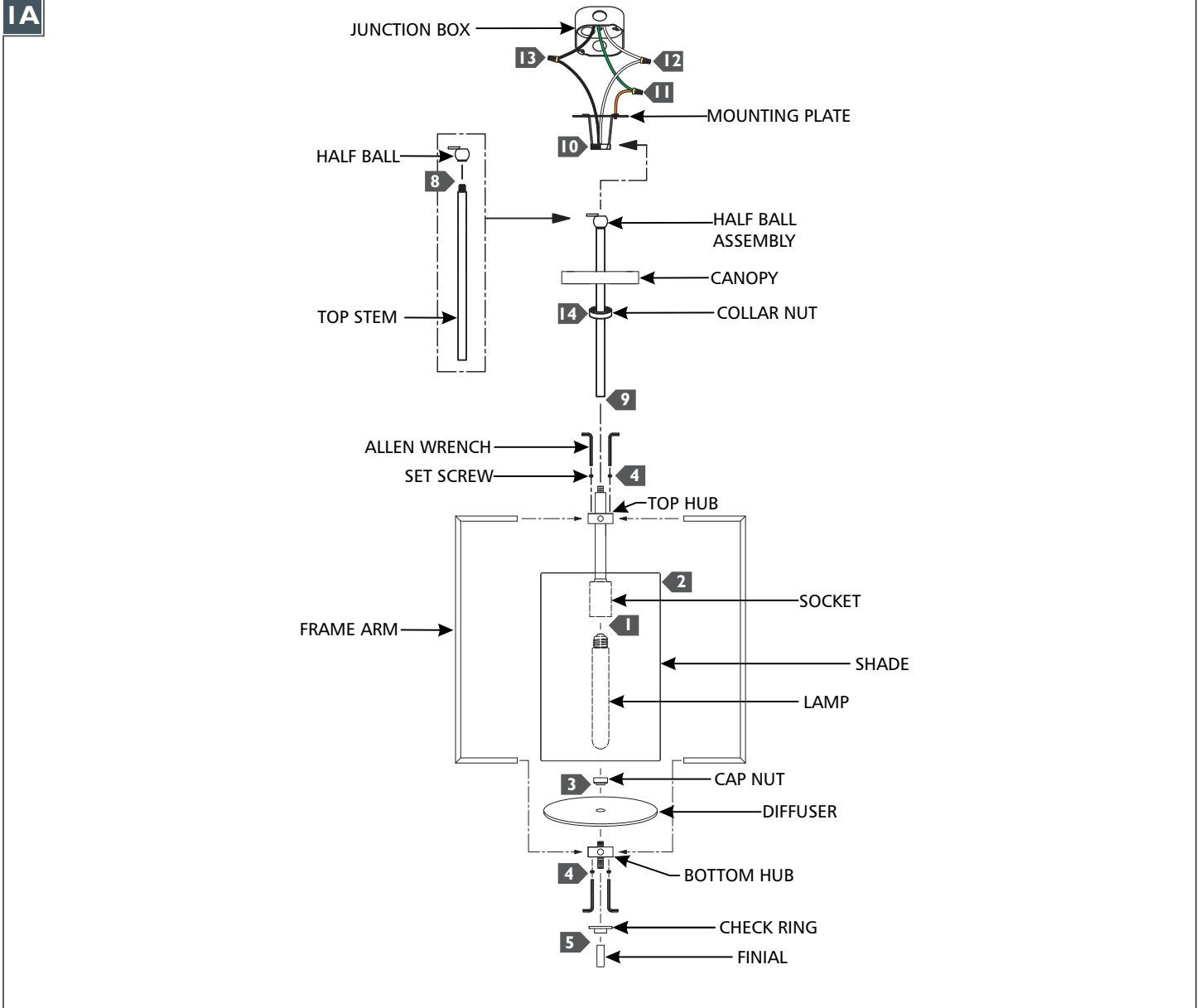

- 1** Screw the lamp into the socket. Refer to the label on the socket for max wattage information.
- 2** Place the shade over the socket.
- 3** Install the diffuser on top of the bottom hub and secure it in place with the cap nut.
- 4** Assemble the fixture frame: install a frame arm by inserting one end in the top hub and the other in the bottom hub/diffuser assembly, then secure it in place with a set screw, using the provided Allen wrench, on both ends. Repeat for all arms.
- 5** Install the check ring onto the threaded nipple and screw the finial in place.
- 6** Determine the wanted height or look of the fixture with the provided stems and assemble them by screwing them together.
- 7** Feed the fixture wires through the stem assembly and screw the assembly to the fixture.
- 8** Screw the half ball to the top stem.
- 9** Feed the fixture wires through the collar nut, canopy, and the half ball assembly then screw it onto the top of the stem/fixture assembly.
- 10** Align and secure the mounting plate to the junction box, then slide the half ball assembly onto the mounting plate.
- 11** Connect the fixture to a suitable ground in accordance with local electrical codes.
- 12** Connect the white fixture wire (square and/or rigid) to the neutral power line wire with a wire nut.
- 13** Connect the black fixture wire (round and/or smooth) to the hot power line wire with a wire nut.
- 14** Neatly place all the wires into the junction box, place the canopy onto the mounting plate, and secure it in place by screwing the collar nut tightly onto the mounting plate.