

## Banda 36 Bath

700BCBND36 | 1.2

VISUAL COMFORT & Co.

MODERN COLLECTION

### GENERAL PRODUCT INFORMATION:



These fixtures are intended to be installed utilizing NEC compliant junction boxes.

Minimum 4" junction box is required for the standard version. The driver is mounted within the fixture base for the T24 version.

This product is suitable for damp locations.

T24 version of this product can be dimmed with most ELV or TRIAC dimmers. Non-T24 version of this product can be dimmed with TRIAC dimmers only.

### CAUTION - RISK OF FIRE

This product must be installed in accordance with the applicable installation code by a person familiar with the construction and operation of the product and the hazards involved.

**Use minimum 90°C supply conductors.**

**SAVE THESE INSTRUCTIONS!**

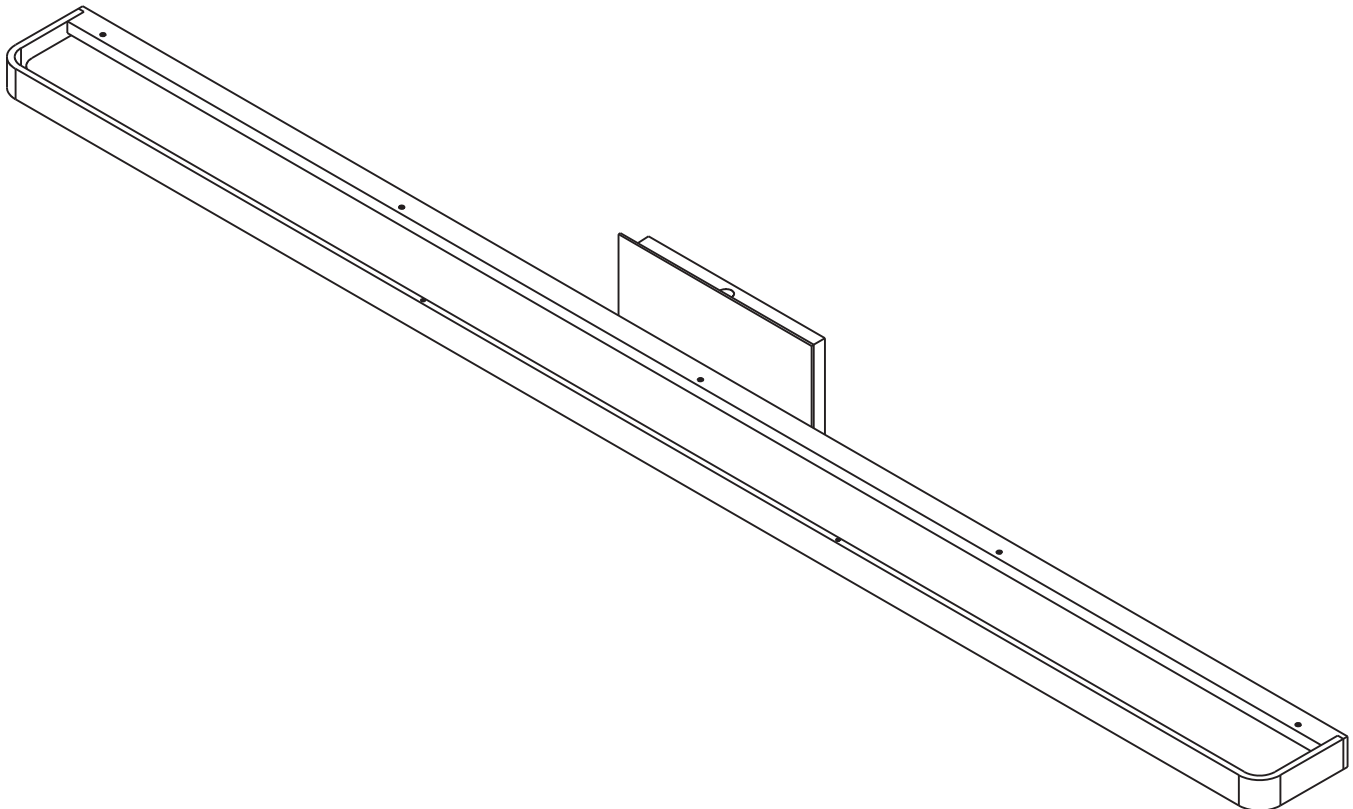

# Install the Fixture

1A

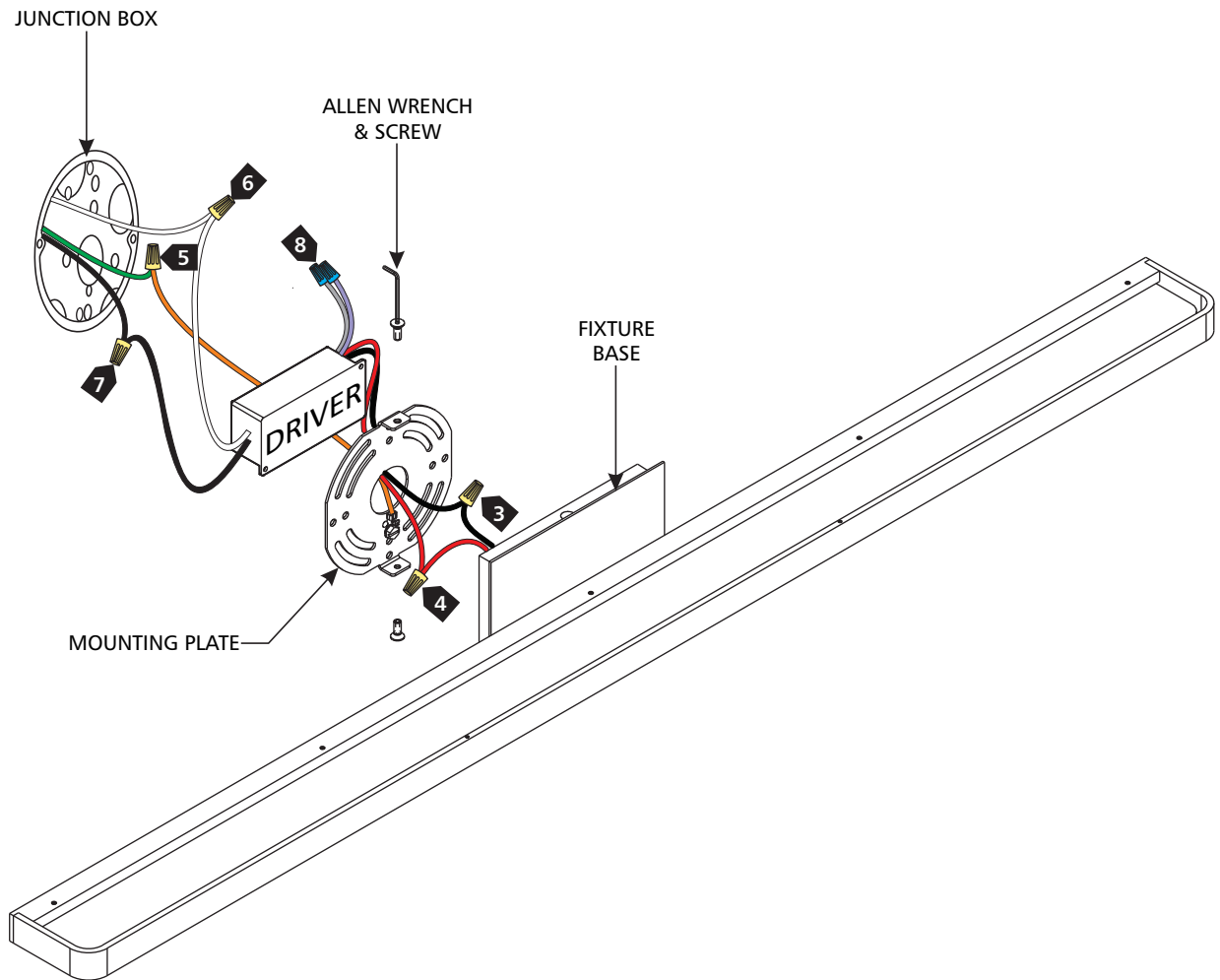

- 1 With the provided Allen wrench, remove the Allen screws on the fixture base.
- 2 Remove the mounting plate from the fixture base
- 3 Connect the black/blue driver wire to the black/blue fixture wire with a wire nut.
- 4 Connect the red driver wire to the red fixture wire with a wire nut.
- 5 Connect the fixture to a suitable ground in accordance with local electrical codes.
- 6 Connect the white driver wire to the neutral power line with a wire nut.
- 7 Connect the black driver wire to the hot power line with a wire nut.
- 8 **For 277V Only:** Connect the purple and gray wires to a compatible dimmer. If not using 0-10V dimming, cap off the purple and gray wires.
- 9 Properly place the driver, all wires, and wire nut connections into the junction box, then install the mounting plate to the junction box with the two #8-32 screws provided. **NOTE: T24 models will have driver mounted inside fixture base, minimum 4" junction box is required otherwise.**
- 10 Mount the fixture base onto the mounting plate and secure it in place by reinstalling the Allen screws using the provided Allen wrench.

VISUAL COMFORT & CO.

7400 Linder Ave., Skokie, IL 60077

T 847.410.4400 | F

847.410.4500

www.visualcomfort.com