

# INSTALLATION INSTRUCTION

## 3020 LED Track Luminaires

H-3020W, L-3020W, J-3020W

# WAC LIGHTING

Responsible Lighting®

### WARNING

IMPORTANT: NEVER attempt any work without shutting off the electricity.

- Read all instructions before installing.
- System is intended for installation by a qualified electrician in accordance with the National Electrical Code and local regulations.
- Place the wall switch in the "OFF" position.
- Go to the main fuse box, or circuit breaker. Switch "OFF" the circuit breaker switch(es) that control the power to the fixture or room that you are working on.

### AVERTISSEMENT

IMPORTANT : Coupez l'électricité avant TOUTE manipulation.

- Lisez toutes les instructions avant d'installer.
- Système est destiné à être installé par un électricien qualifié en conformité avec le code national de l'électricité et les règlements locaux.
- Placez l'interrupteur mural en position d'arrêt (« OFF »).
- Accédez au panneau central de disjoncteurs ou de fusibles de votre demeure et placez l'interrupteur principal en position d'arrêt (« OFF »).

All parts must be used as indicated in these instructions. Do not substitute any parts, leave parts out, or use any parts that are worn out or broken. Failure to follow this instruction could invalidate the UL/cUL listing of this fixture.

### OVERVIEW:

Fixtures are designed for use on WAC Lighting's track systems.

LED TRACK FIXTURE	TRACK SYSTEMS
H-3020W Series	H Track
L-3020W Series	L Track
J-3020W Series	J and J2 Track

### INSTALLING ON TRACK:

1. Align the alignment tab on the adapter with the groove/slot on the track (Figure 1).
2. Once aligned, insert adapter into track slot and rotate it 90°. The arrow should point to the grooved side of the track (Figure 2).
3. Make sure the alignment tab seats in the track slot
4. Reverse procedure to remove.  
Enter track luminaire may be positioned anywhere along the track length.

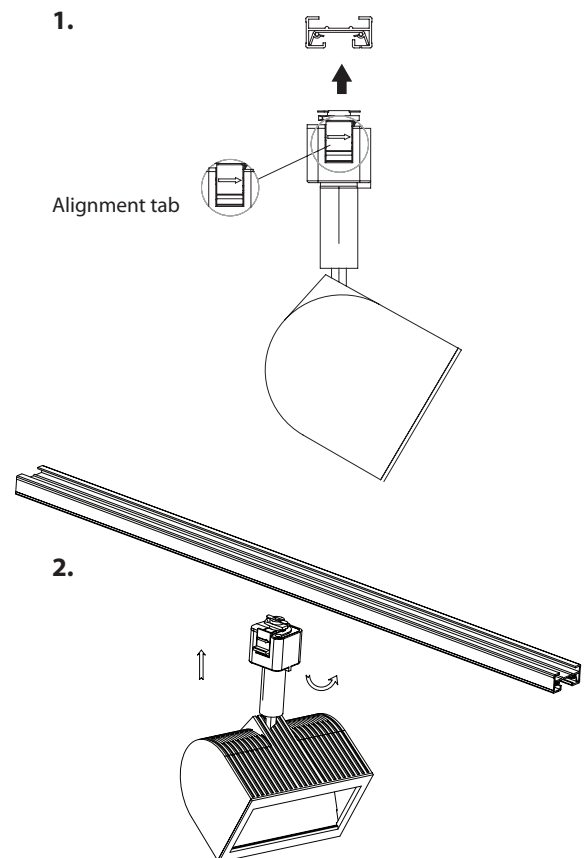

WAC Lighting  
www.waclighting.com  
Phone (800) 526.2588 • Fax (800) 526.2585

Headquarters/Eastern Distribution Center  
44 Harbor Park Drive • Port Washington, NY 11050  
Phone (516) 515.5000 • Fax (516) 515.5050

Western Distribution Center  
1750 Archibald Ave • Ontario, CA 91761  
Phone (800) 526.2588 • Fax (800) 526.2585