

INSTALLATION INSTRUCTION

Exterminator II - LED Monopoint

MO-1052



SAFETY INSTRUCTION

IMPORTANT: NEVER attempt any work without shutting off the electricity.

- Read all instructions before installing.
- System is intended for installation by a qualified electrician in accordance with the National Electrical Code and local regulations.
- Go to the main fuse box, or circuit breaker. Place the main power switch in the "OFF" position and unscrew the fuse(s) or switch "OFF" the circuit breaker switch(es) that control the power to the fixture or room that you are working on.
- Place the wall switch in the "OFF" position.

CAUTION

- All parts must be used as indicated in these instructions. Do not substitute any parts, leave parts out, or use any parts that are worn out or broken. Failure to follow this instruction could invalidate the UL/CUL listing of this fixture.

AVERTISSEMENT

IMPORTANT : Coupez l'électricité avant TOUTE manipulation.

- Lisez toutes les instructions avant d'installer.
- Système est destiné à être installé par un électricien qualifié en conformité avec le code national de l'électricité et les règlements locaux.
- Accédez au panneau central de disjoncteurs ou de fusibles de votre demeure et placez l'interrupteur principal en position d'arrêt («OFF »).
- Placez l'interrupteur mural en position d'arrêt (« OFF »).

MISE EN GARDE

- Toutes les pièces doivent être utilisées tel qu'il est indiqué dans ces instructions. Ne remplacez pas les pièces, n'en laissez pas de côté et ne les utilisez pas si elles sont usées ou brisées. Le non-respect de ces instructions peut annuler l'homologation UL/CUL du luminaire.

| Electrical Data | |
|---------------------------|--|
| INPUT VOLTAGE | 120-277V AC, 50/60Hz |
| INPUT CURRENT (120V/277V) | 1052S: 0.30A/0.13A 1052N,F: 0.38A/0.17A |
| DIMMING | ELV, TRIAC, 0-10V |

INSTALLING LAMP: (Fig.1)

1. Loosen the three canopy screws, twist and separate the canopy cover from the base plate. (keep screws on base plate)
2. Remove a knock out from the base plate.
3. Attach the base plate to the surface using slotted holes for mounting screws (supplied).
4. Connect fixture wires to AC power wire, with wire nuts (supplied).
5. Connect ground wire to the green wire from fixture.
6. Mount the canopy to the base plate by twisting key holes over three screws in base plate.
7. Tighten screws to secure canopy.
8. After the light is on, rotate the luminaire body horizontally or vertically to aim properly.

FIG.1

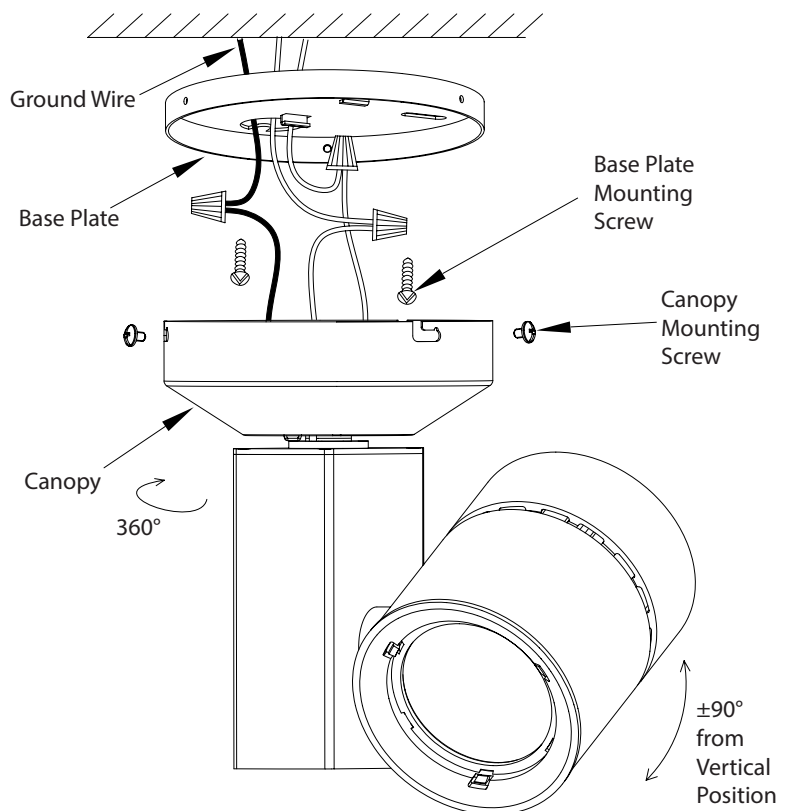

Note: All parts must be used as indicated in these instructions. Do not substitute any parts, leave parts out, or use any parts that are worn out or broken. Failure to follow this instruction could invalidate the UL/CUL listing of this fixture.

ACCESSORIES: (Fig. 2)

1. Use a screw-driver to loosen the two screw at the back of the fixture body.
2. Take out the front frame, then change the lens.
3. To install cross louver or snoot, use the clips around the front frame to fasten them directly.

FIG.2

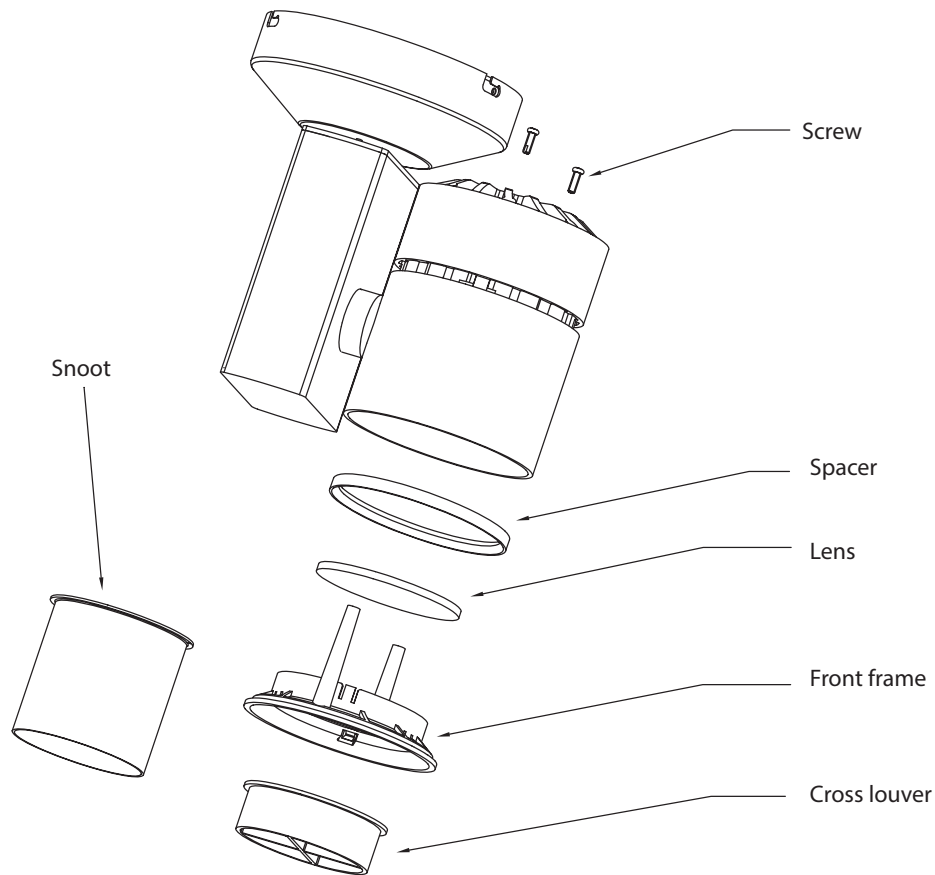

Aligning the Reflector (Fig. 3)

Before putting the accessory assembly back to the fixture, make sure to align the reflector properly as shown in **Fig. 3**.

Fig. 3

