



SPECIAL INSTALLATION

GENERAL PRODUCT INFORMATION:



This product is suitable for indoor dry locations only.

This product is intended for use with Tech Lighting MonoRail system only.

NOTE: This product must be used in concurrent with the MonoRail standoff and power vault adapter.

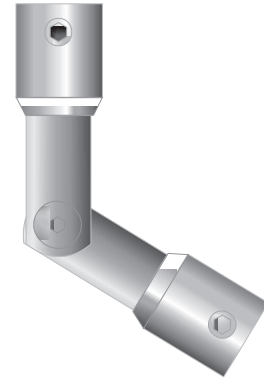

Install the Hardware

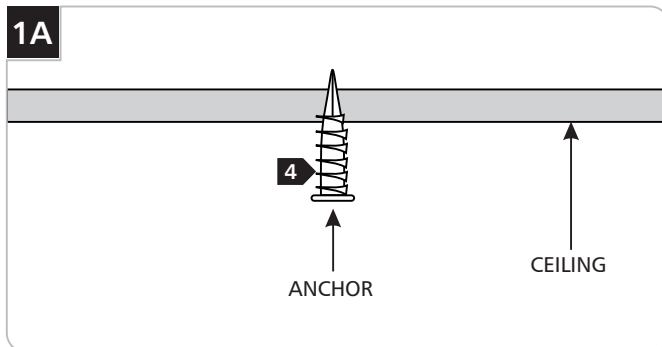

NOTE: The hardware package is provided with the standoffs.

- 1** Select a location on the ceiling where the MonoRail is to be mounted.
- 2** One way of marking the standoff locations on the ceiling is to lay the MonoRail on the floor underneath of the selected location and by using a plumb bob pointing on the center of the MonoRail mark the points on the ceiling.
- 3** The other way is to hold the MonoRail directly against the ceiling and mark the standoff points on the ceiling.
- 4** Tap the anchors at the marked points up to the threaded portion with a hammer.

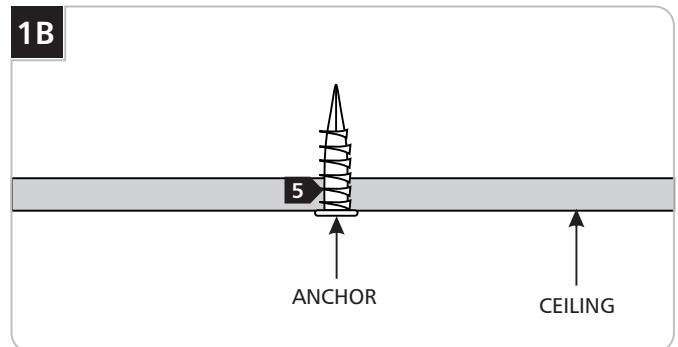

- 5** Screw the anchors in the rest of the way with a Phillips screwdriver.

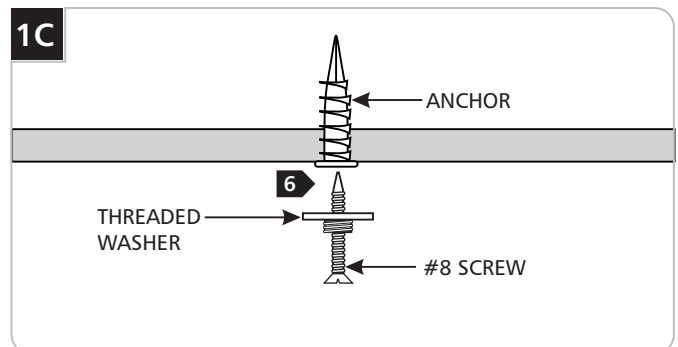

- 6** Attach the threaded washer to the anchor with the #8 screw.

1D

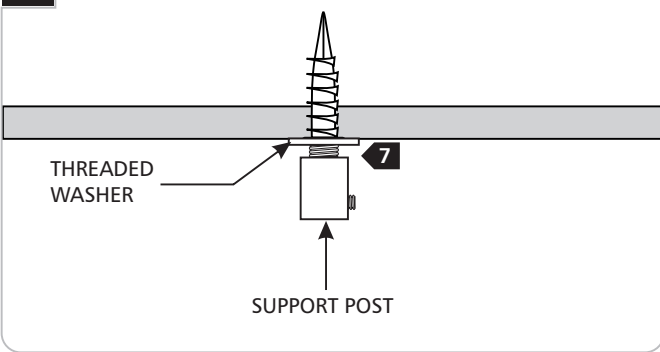

7 Screw the support posts to the threaded washers.

Standoff Vault Adapter Installation for MonoRail Power Feed Canopy or Electronic Surface Transformer with Power Connector Mounted on the Ceiling

2A

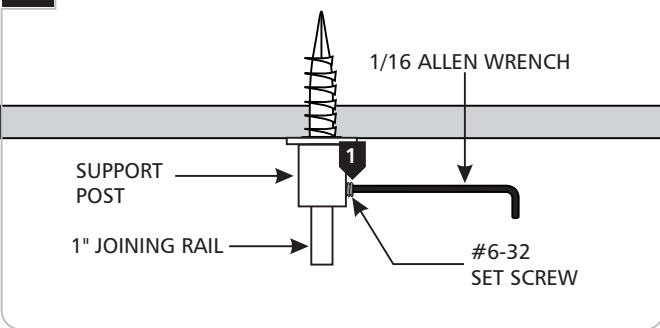

1 Insert the 1" Joining rail (provided with the vault adapter) all the way into the support post and tighten the #6-32 set screw with the 1/16 Allen wrench.

2B

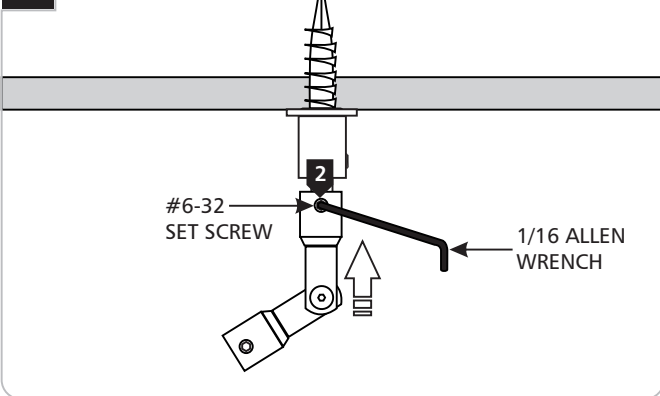

2 Push the vault standoff connector all the way onto the 1" joining rail and tighten the #6-32 set screw so that the connector is oriented in the proper direction.

Standoff Vault Adapter Installation for MonoRail Magnetic or Electronic Surface Transformer

3A

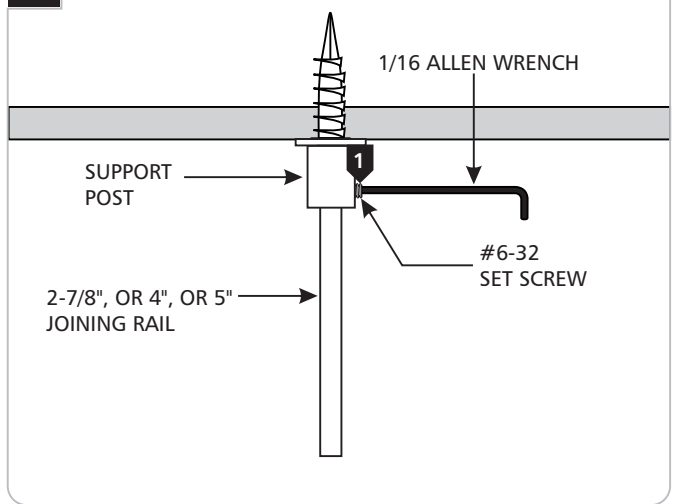

1 Insert the 2-7/8" joining rail (when 150 watt magnetic surface mount transformer is used with the system), or the 4" joining rail (when 300 watt magnetic surface mount transformer is used with the system), or 5" joining rail (when 600 watt magnetic or 300 watt electronic surface mount transformer is used with the system) all the way into the support post and tighten the #6-32 set screw with the 1/16 Allen wrench.

3B

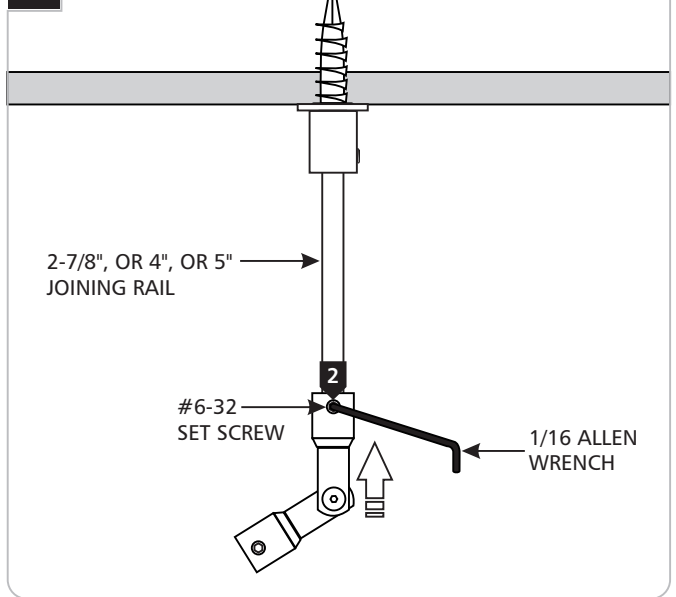

2 Push the vault standoff connector all the way onto the joining rail and tighten the #6-32 set screw so that the connector is oriented in the proper direction.

Mounting MonoRail Rigid Standoff to the Standoff Vault Adapter When the Power Feed is not Extended

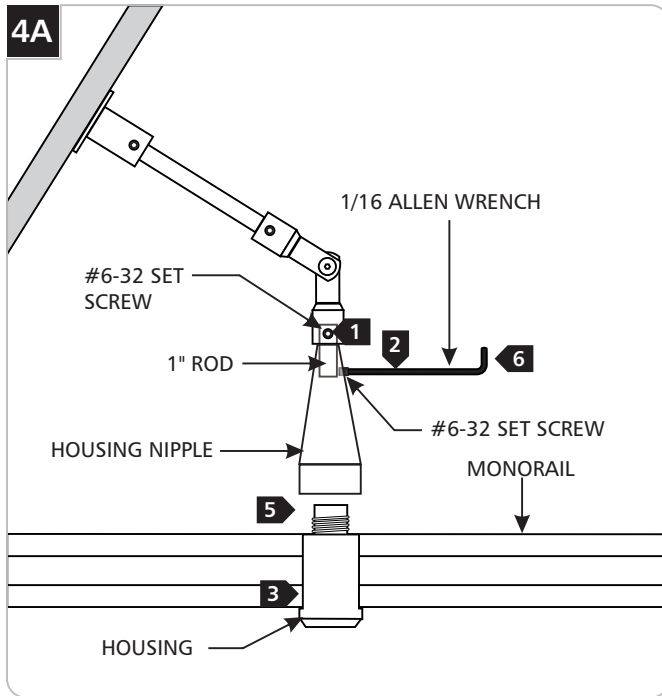

- 1** Insert the 1" joining rail (provided with the vault adapter) all the way into the vault adapter and tighten the #6-32 set screw with the 1/16 Allen wrench.
- 2** Push the housing nipple completely onto the 1" joining rail and tighten the #6-32 set screw snugly with the 1/16 Allen wrench.
- 3** Put the MonoRail into the housing.
- 4** Loosen the #6-32 set screw on the housing nipple with the 1/16 Allen wrench so that it could turn easily.
- 5** Screw the housing nipple onto the housing tight by turning the housing nipple clockwise.
- 6** Tighten the #6-32 set screw on the housing nipple with the 1/16 Allen wrench.

Mounting MonoRail Rigid Standoff to the Standoff Vault Adapter When the Power Feed is Extended

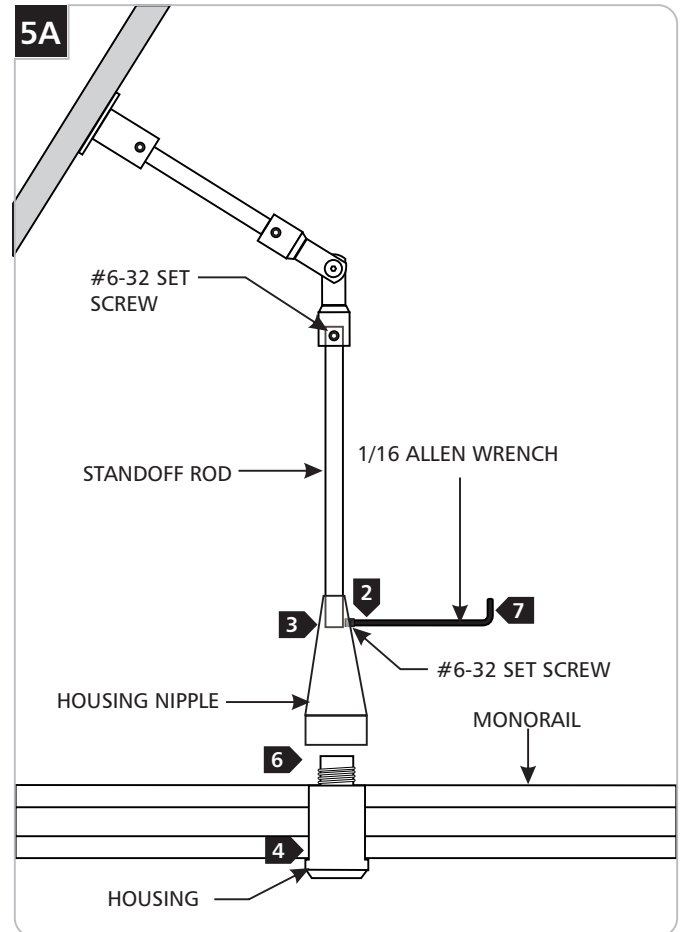

NOTE: Cut the rod provided with the standoff 1" shorter to match with the power feed extension rod.

- 1** Cut the standoff rod (provided with the standoff adapter) 1" shorter.
- 2** Insert the standoff rod completely into the vault adapter and tighten the #6-32 set screw with the 1/16 Allen wrench.
- 3** Push the housing nipple completely onto the standoff rod and tighten the #6-32 set screw snugly with the 1/16 Allen wrench.
- 4** Put the MonoRail into the housing.
- 5** Loosen the #6-32 set screw on the housing nipple with the 1/16 Allen wrench so that it could turn easily.
- 6** Screw the housing nipple onto the housing tight by turning the housing nipple clockwise.
- 7** Tighten the #6-32 set screw on the housing nipple with the 1/16 Allen wrench.

Mounting MonoRail Adjustable Standoff to the Standoff Vault Adapter

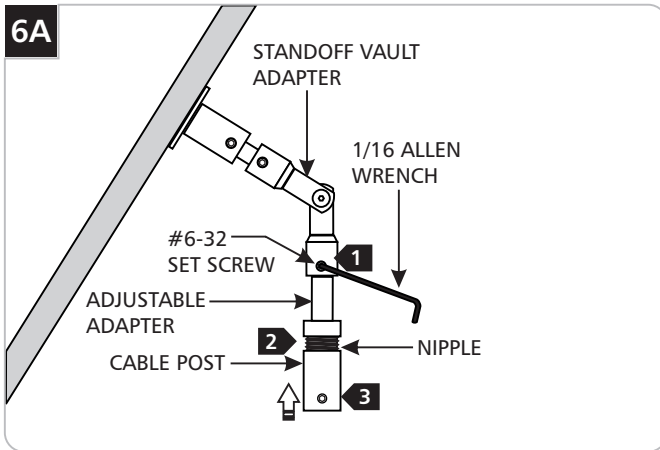

- 1** Insert the adjustable adapter all the way into the standoff vault adapter and tighten the #6-32 set screw with the 1/16 Allen wrench.
- 2** Screw the short nipple completely into the adjustable adapter.
- 3** Screw the cable post all the way onto the nipple.

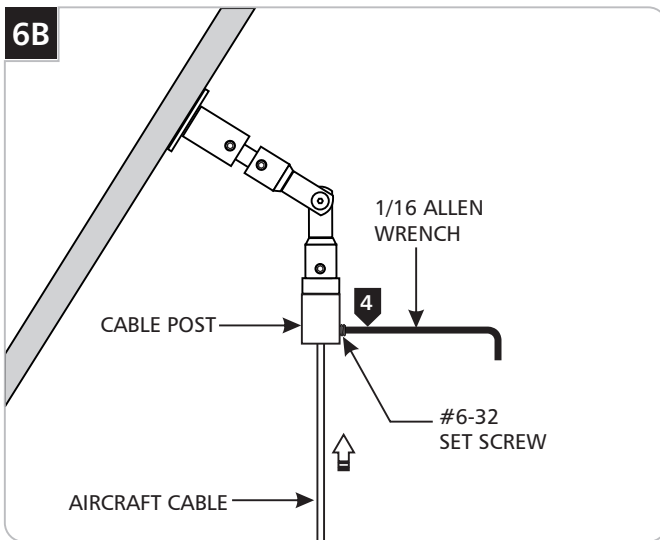

- 4** Insert the aircraft cable all the way into the cable post and tighten the #6-32 set screw with the 1/16 Allen wrench.

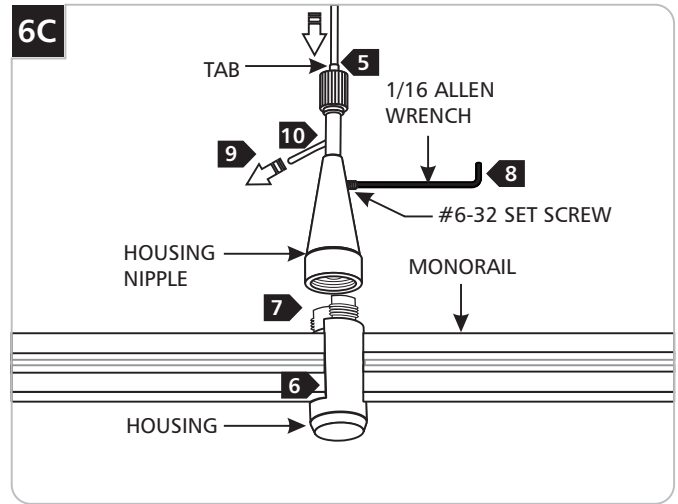

- 5** Feed the aircraft cable through the wire grip by pushing the tab down. Pull the aircraft cable through the hole on the post.
- 6** Place the MonoRail into the housing.
- 7** Loosen the #6-32 set screw on the housing nipple so that it could turn easily and screw the housing nipple to the housing tight.
- 8** Tighten the #6-32 set screw with the 1/16 Allen wrench.
- 9** Adjust the standoff height by pulling the aircraft cable and pushing the tab down.
- 10** After achieving the desired standoff height, trim off excess aircraft cable coming out of the wire grip post.

SAVE THESE INSTRUCTIONS!



7400 Linder Ave, Skokie, IL 60077
847.410.4400

www.techlighting.com

© 2008 Tech Lighting, L.L.C. All rights reserved. The "Tech Lighting" graphic is a registered trademark of Tech Lighting, L.L.C. Tech Lighting reserves the right to change specifications for product improvements without notification.
A Generation Brands Company