

## INSTALLATION INSTRUCTION

### 2.5" Low Voltage - Electronic Non-IC New Construction

HR-802

# WAC LIGHTING

Responsible Lighting®

#### SAFETY INSTRUCTION

IMPORTANT: NEVER attempt any work without shutting off the electricity.

- Always turn off power at fuse box prior to installation to prevent electrical shock.
- Do not install insulation within 3" of housing.

#### MOUNTING:

1. Supplied with two hanger bars, (24" max). Bars can be used on both sides and are notched on the ends to fit over "T" bars in suspended ceilings. Hanger bars include a captive mounting "screw-nail" for ease of installation.
2. Align the bottom of the hanger bar with the bottom of the wood joist.
3. Secure the "screw-nail" on each end by screwdriver (as fig A), or by hammer (as fig B).
4. Position housing so that the rim is flush with the ceiling opening.
5. Draw supply wire ( 1/2" trade size flexible metal conduit or Romex wire ) from ceiling to fixture site.
6. To make electrical connections:
  - a. Remove the junction box cover on the housing.
  - b. Connect supply wire to junction box opening with suitable connector.
  - c. Connect black transformer wire to black supply wire with wire nut.
  - d. Connect white transformer wire to white supply wire with wire nut.
  - e. Connect green grounding wires with wire nut. ( Supply may be green or un-insulated)
  - f. Close junction box cover and tighten screw.

Note: The electronic transformer in this housing has the following features:

- Electronic short circuit protection with automatic reset.
- Overload protection with automatic reset.
- "Soft Start" to prolong lamp life.
- Compatible with most standard incandescent dimmers.

This housing is designed for use with an MR16 lamp of 12 volts 50 watts or less. If a lamp greater than 50 watts is used, the built-in thermal protector will cause the lamp to blink, indicating an overheating situation.

If damaged is caused to the socket, the part number HR-8000-SOCKET can be ordered in replacement.

Retain instructions for maintenance reference.

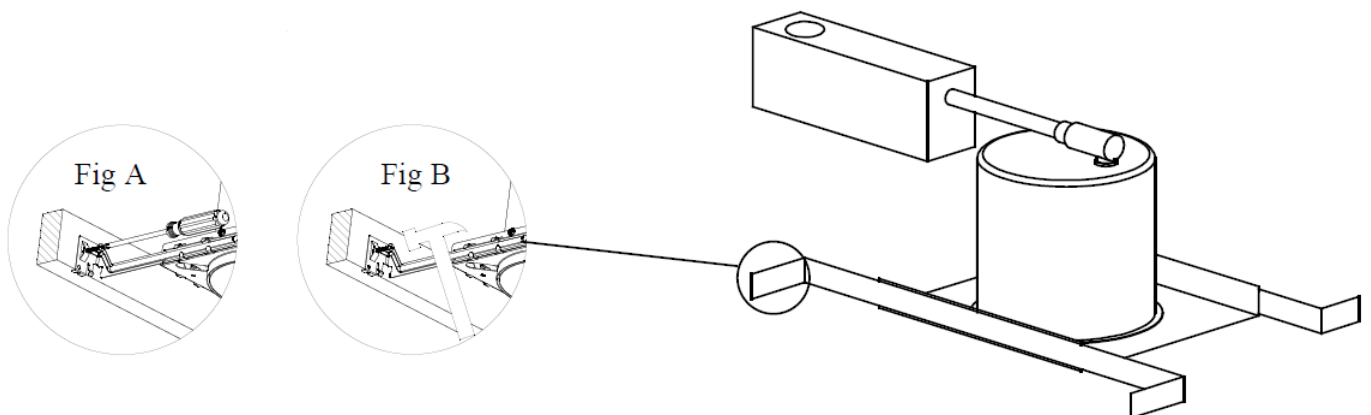

WAC Lighting  
www.waclighting.com  
Phone (800) 526.2588 • Fax (800) 526.2585

Headquarters/Eastern Distribution Center  
44 Harbor Park Drive • Port Washington, NY 11050  
Phone (516) 515.5000 • Fax (516) 515.5050

Western Distribution Center  
1750 Archibald Ave • Ontario, CA 91761  
Phone (800) 526.2588 • Fax (800) 526.2585